

DS453Q/DS455Q



Security Systems

EN | Installation Instructions
Photoelectric Detectors

BOSCH

Contents

1.0	General Description	4
1.1	Features	4
1.2	Components	4
2.0	Installation Considerations	5
3.0	Mounting	6
3.1	Pole Mounting.....	6
3.2	Wall Mounting.....	7
4.0	Wiring	8
4.1	Terminals.....	8
4.2	Wiring Distance	8
4.3	Wiring Route.....	8
5.0	Special Features	9
5.1	Level Meter	9
5.2	Environmental Discrimination Circuit (EDC)	9
5.3	Beam Interruption Time	10
5.4	Beam Power Control.....	10
6.0	Setup and Alignment	10
6.1	Bypass Switch.....	10
6.2	Interruption Time	10
6.3	Beam Power Control.....	11
6.4	Alignment.....	11
6.4.1	Alignment by LED	11
6.4.2	Alignment Using a Voltmeter	12
7.0	Tests	12
7.1	Walk Test.....	12
7.2	EDC Test.....	12
7.3	Tamper Test	13
8.0	Troubleshooting Guide	13
9.0	Other Information	14
10.0	Specifications	14

Figures

Figure 1:	Internal Components.....	4
Figure 2:	Transmitter Panel.....	4
Figure 3:	Receiver Panel.....	4
Figure 4:	Beam Spread	5
Figure 5:	Use of Mounting Bracket Flange based upon Pole Diameter.....	6
Figure 6:	Attaching the Mounting Bracket.....	6
Figure 7:	Back-to-Back Mounting.....	6
Figure 8:	Attaching the U-clamp	7
Figure 9:	Wall Mounting	7
Figure 10:	Transmitter Wiring	8
Figure 11:	Wiring for One Set on the Run.....	8
Figure 12:	Wiring for Two Sets on the Run	8
Figure 13:	Level Meter	9
Figure 14:	Beam Strength Over Distance.....	10
Figure 15:	Setting the Bypass Switch and Interruption Time	10
Figure 16:	Transmitter Beam Power Control.....	11
Figure 17:	Installing the Interruption Sheets.....	11
Figure 18:	Alignment Using Scope and LEDs.....	11
Figure 19:	Terminals on Receiver Panel	12
Figure 20:	Walk Test.....	12

Tables

Table 1:	Beam Spread Distances.....	5
Table 2:	Maximum Wiring Distance	8
Table 3:	Using the Bypass Switch	9
Table 4:	Interruption Time Examples	10
Table 5:	Outdoor Beam Power Control Settings..	11
Table 6:	Troubleshooting Guide	13
Table 7:	Specifications	14

1.0 General Description

The DS453Q/DS455Q are quad photoelectric detectors. Through four pulsed infrared beams, they activate an alarm relay when detecting an intruder.

1.1 Features

For stable operation, the DS453Q and DS455Q are equipped with the following features:

100% Sensitivity Allowance: Maintains stable operation even if 99% of beam energy is cut by rain, fog, frost, and so on.

Quad Beam Detection: Fewer false alarms caused by birds and other small animals because all four beams must be blocked simultaneously to cause an alarm.

Beam Power Control: Select the appropriate beam intensity relative to the detection range to minimize reflection on nearby walls and cross-talk with other detectors.

Beam Interruption Time Control: Use to change the beam interruption time to best fit the application.

1.2 Components

Figure 1: Internal Components

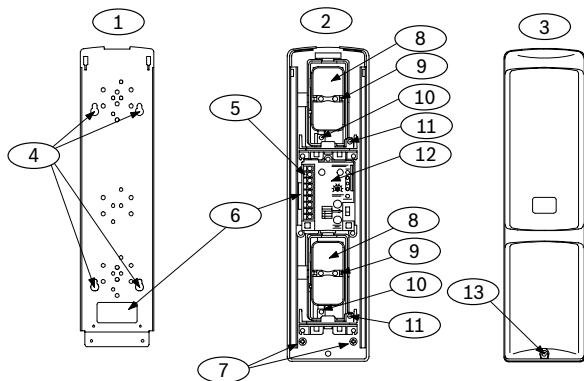

- | | |
|----------------------------|--|
| 1 - Chassis | 9 - Scope |
| 2 - Detector base | 10 - Vertical adjustment screw |
| 3 - Cover | 11 - Horizontal adjustment screw |
| 4 - Chassis mounting holes | 12 - Operation panel (transmitter or receiver) |
| 5 - Terminal | 13 - Cover mounting screw |
| 6 - Wire entrance | |
| 7 - Base mounting screws | |
| 8 - Optical module | |

Figure 2: Transmitter Panel

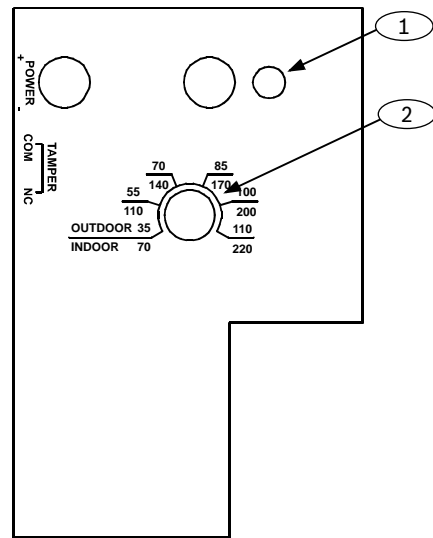

- 1 - Monitor LED
- 2 - Beam power control

Figure 3: Receiver Panel

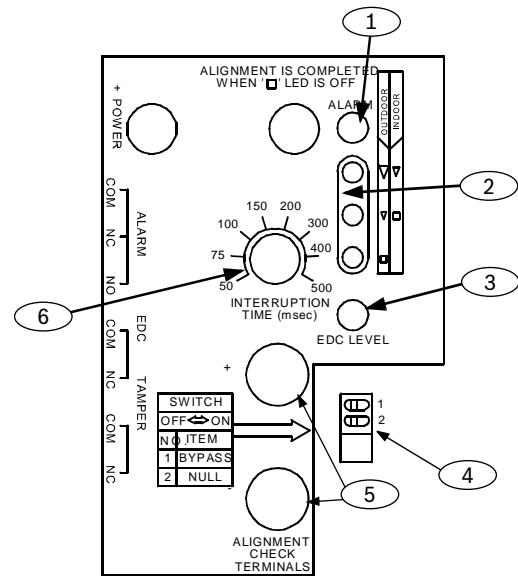

- 1 - Alarm LED
- 2 - Level meter
- 3 - EDC LED (environmental discrimination circuit)
- 4 - Bypass switch
- 5 - Alignment check terminals
- 6 - Sensitivity volume

2.0 Installation Considerations



- Keep the beam path clear of objects.
- Install the transmitter and receiver within the maximum protection range of the model.
- Do not install the receivers where they face an intense source of light (such as a rising or setting sun). A foreign light coming within a ± 3 degree angle of each receiver axis can cause false alarms.
- Do not install either detector on movable surfaces or surfaces subject to vibrations.
- Do not install the detectors where they are subject to strong electromagnetic noise.
- Do not use the detectors with another photoelectric detector's receiver or transmitter.
- Do not stack the detectors. The DS453Q and DS455Q are **non-stackable** detectors.
- Avoid extreme temperature and humidity.
- Avoid magnets or any magnetized material.

Beam Spread

The beam spread angle is ± 0.7 degrees from the transmitter (Figure 4, Item 4) to the receiver (Figure 4, Item 5). Refer to Table 1 and Figure 4 to determine the installation conditions.

Table 1: Beam Spread Distances

Beam Distance ¹		Horizontal Spread ²		Vertical Spread ³	
m	ft	m	ft	m	ft
20	65	0.5	1.6	0.8	2.6
40	131	1.0	3.3	1.3	4.3
60	197	1.5	5.0	1.8	5.9
80	263	2.0	6.6	2.2	7.2
110	361	2.7	8.9	3.0	9.8
140	459	3.5	11.5	3.7	12.1
160	525	4.0	13.1	4.2	13.8
20	65	0.5	1.6	0.8	2.6

¹ Refer to Item 1 in Figure 4.
² Refer to Item 2 in Figure 4.
³ Refer to Item 3 in Figure 4.

Figure 4: Beam Spread

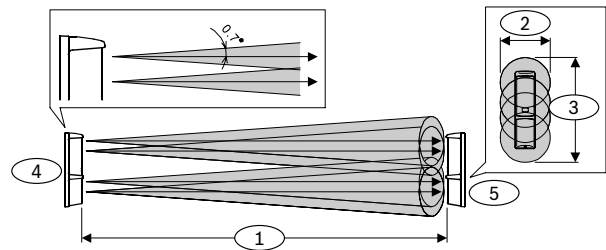

- 1 - Beam distance
- 2 - Horizontal spread
- 3 - Vertical spread
- 4 - Transmitter
- 5 - Receiver

3.0 Mounting

3.1 Pole Mounting

1. Choose an appropriate mounting location for the system.
2. Install the poles with a clear line-of-sight between the transmitter and the receiver.
3. Loosen the transmitter's cover mounting screw and remove the cover. Refer to *Figure 1* on page 4.
4. Loosen the two base mounting screws and remove the chassis by sliding it down the unit. Refer to *Figure 1* on page 4.
5. If the pole's diameter is between 38.1 mm (1.5 in.) and 40.6 mm (1.6 in.), turn the mounting bracket so the longer flange is in a vertical position against the pole (*Figure 5, Item 1*). If the pole's diameter is between 40.6 mm (1.6 in.) and 43.2 mm (1.7 in.), turn the mounting bracket so the shorter flange is vertical against the pole (*Figure 5, Item 2*) is vertical against the pole.

Figure 5: Use of Mounting Bracket Flange based upon Pole Diameter

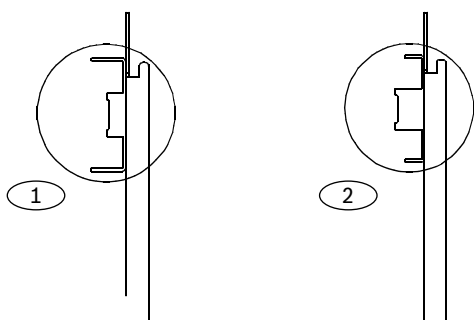

- 1 - Longer flange in vertical position
- 2 - Shorter flange in vertical position

6. Use the short clamping screws to attach the mounting brackets to the chassis. (Refer to *Figure 6*).

Figure 6: Attaching the Mounting Bracket

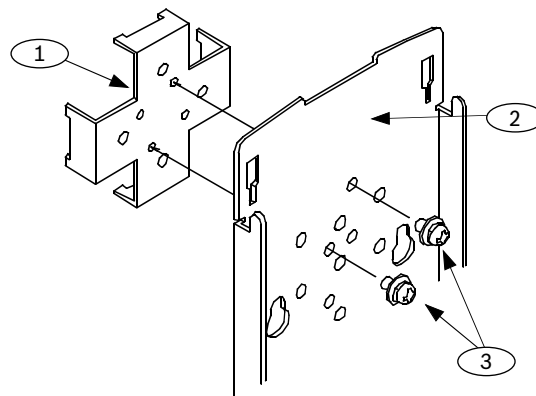

- 1 - Mounting bracket
- 2 - Chassis
- 3 - Clamping screws (short)



If mounting a transmitter and receiver back-to-back on the same pole, refer to *Figure 7* for the correct locations of the mounting holes.

Figure 7: Back-to-Back Mounting

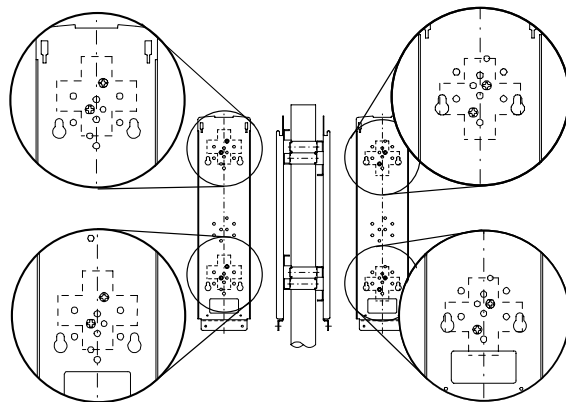

- Use the U-clamps and the long screws to attach the chassis firmly to the poles. Refer to *Figure 8*.



Make sure the transmitter is mounted in a direct line of sight with the receiver.

Figure 8: Attaching the U-clamp

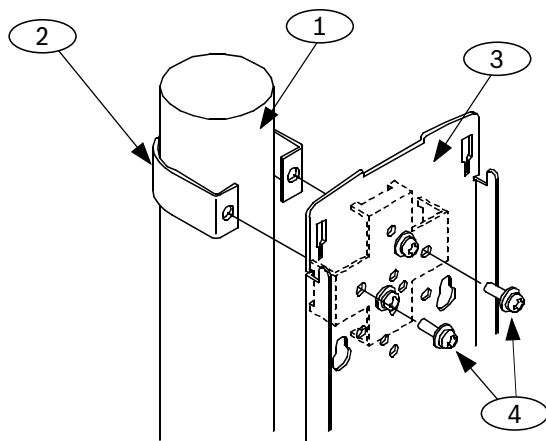

- 1 - Chassis
- 2 - Pole
- 3 - U-clamp
- 4 - Long screws

- Route wiring through the chassis wire entrance, leaving enough wire to access the transmitter's terminal strip. Refer to *Item 4* in *Figure 9*.
- Route wiring through the transmitter wire entrance. Refer to *Item 5* in *Figure 9*.
- Slide the transmitter onto the chassis.
- Tighten the unit with the mounting screws.
- Repeat this mounting process for the receiver.

3.2 Wall Mounting

- Loosen the transmitter's cover mounting screw and remove the cover. Refer to *Figure 1* on page 4
- Loosen the two unit mounting screws and remove the chassis by sliding it down the unit. Refer to *Figure 9*.
- Insert wiring through the chassis wire entrance. Leave enough wire to access the transmitter's terminal strip.
- Use the chassis mounting screws to mount the chassis to the mounting surface. Refer to *Figure 9*.
- Route wiring through the transmitter wire entrance. Refer to *Figure 9*.
- If surface mounting is used, knock-out the thin-wall wire entrance at the bottom of the transmitter. Refer to *Figure 9*.

- Reattach the transmitter to the chassis.
- Repeat this mounting procedure for the receiver.



Make sure the transmitter and receiver are mounted in a direct line of sight with each other.

Figure 9: Wall Mounting

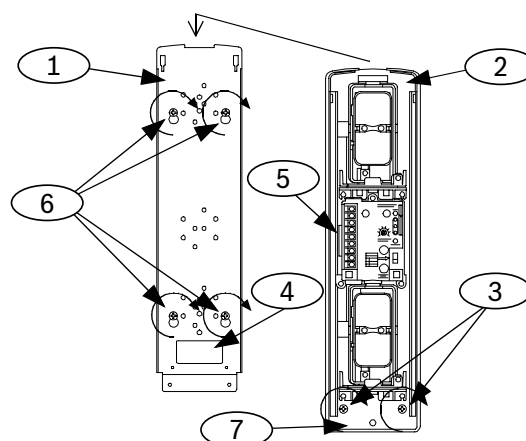

- 1 - Chassis
- 2 - Detector base
- 3 - Mounting screws
- 4 - Chassis wire entrance
- 5 - Transmitter wire entrance
- 6 - Chassis mounting screws
- 7 - Thin-wall wire entrance

4.0 Wiring



Apply power only **after** all connections are made and inspected.

4.1 Terminals

Figure 10: Transmitter Wiring

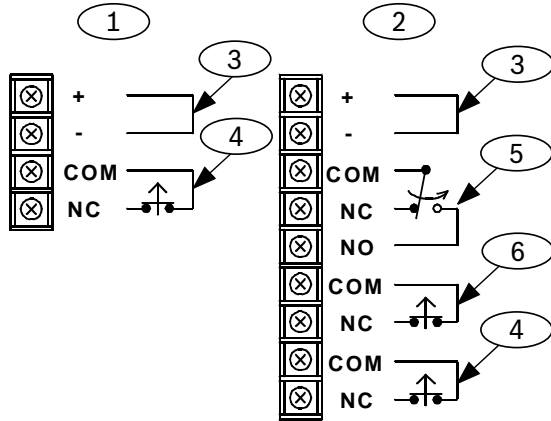

- 1 - Transmitter wiring
- 2 - Receiver wiring
- 3 - Power
10.5 VDC to 28.0 VDC
- 4 - Tamper Output
30 VDC 0.1 A
- 5 - Alarm output
30 VDC 0.2 A
- 6 - EDC output (environmental discrimination circuit)
30 VDC 0.2 A

4.2 Wiring Distance

Use *Table 2* to determine the minimum wire gauge for a single detector system (one transmitter and one receiver). The distances specified are between the power source and the last unit on the run. For multiple detector systems, divide the wire distance specified in the table by the number of systems on the run (1 system = 1 transmitter + 1 receiver).

Table 2: Maximum Wiring Distance

Wire Gauge	DS453Q		DS455Q	
	12 VDC	24 VDC	12 VDC	24 VDC
22 AWG	80 m (263 ft)	730 m (2395 ft)	60 m (197 ft)	610 m (2001 ft)
19 AWG	150 m (492 ft)	1420 m (4659 ft)	130 m (427 ft)	1200 m (3937 ft)
17 AWG	280 m (919 ft)	2580 m (8465 ft)	240 m (787 ft)	2180 m (7152 ft)
14 AWG	500 m (1640 ft)	4570 m (14993 ft)	420 m (1378 ft)	3860 m (12664 ft)

4.3 Wiring Route



A "set" is one transmitter and one receiver.

Figure 11: Wiring for One Set on the Run

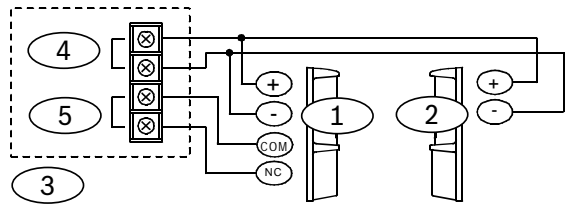

- 1 - Receiver
- 2 - Transmitter
- 3 - Control device
- 4 - Power output
- 5 - Alarm input (NC)

Figure 12: Wiring for Two Sets on the Run

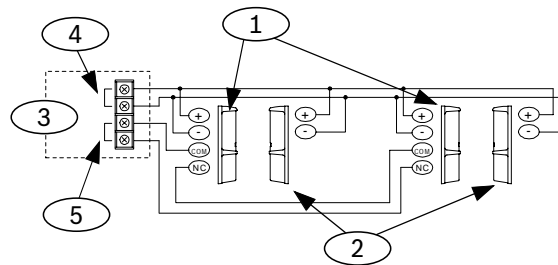

- 1 - Receiver
- 2 - Transmitter
- 3 - Control device
- 4 - Power output
- 5 - Alarm input (NC)



Connect tamper and EDC (environmental discrimination circuit) terminals to a 24-hour supervisory loop.

5.0 Special Features

5.1 Level Meter

Three LEDs on the receiver panel display the amount of beam energy received. Refer to *Figure 13*. As more beam energy is received, each LED follows this sequence:

ON→Flashes quickly→Flashes slowly⇒OFF

Alignment is complete when the LED marked with a square turns off.



The LEDs have different marks for "INDOOR" and "OUTDOOR" installations.

Figure 13: Level Meter

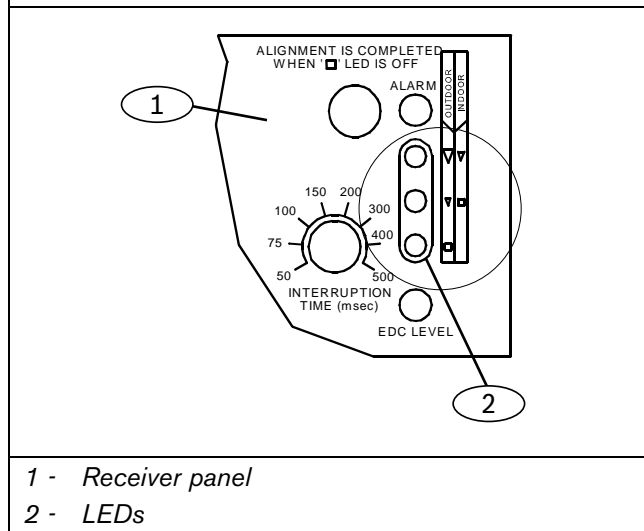

1 - Receiver panel

2 - LEDs

5.2 Environmental Discrimination Circuit (EDC)

EDC sends an EDC signal when it becomes difficult to maintain stable operation due to environmental disturbances like fog or rain. *Table 3* describes the operation of the bypass switch.

In poor environmental conditions, an unfavorable environment exists where stable operation cannot be maintained for more than three seconds.



The EDC feature was not evaluated by Underwriters laboratories (UL).

Table 3: Using the Bypass Switch

Bypass Switch State	Condition	Description
Off	Poor environmental condition	EDC LED turns on. The EDC signal is provided through the receiver's normal closed relay output. The alarm signal is generated by the further loss of the beam energy.
	Either optical module is blocked for 3 seconds	EDC LED turns on. The EDC signal is provided through the receiver's normal closed relay output. No alarm output is generated.
	Both optical modules are blocked for 2 seconds	After the specified interruption time, the alarm LED turns on and an alarm signal is generated. If the beams are blocked for more than 3 seconds, EDC LED turns on and EDC signal is provided through the receiver's normal closed relay output.
On	Poor environmental condition	EDC LED turns on. The EDC signal is provided through the receiver's normal closed relay output. With the further loss of beam energy, the alarm LED turns on but the alarm signal is not generated (alarm relay is automatically shunted).
	Either optical module is blocked for 3 seconds	EDC LED turns on. The EDC signal is provided through the receiver's normal closed relay output. If another optical module is blocked, the alarm LED turns on but no alarm signal is generated.
	Both optical modules are blocked for 2 seconds	After the specified interruption time, the alarm LED turns on and alarm signal is generated. Even if the beams are blocked for more than 3 seconds, EDC LED does not turn on and an EDC signal is not provided through the receiver's normal closed relay output.



Connect the EDC to a trouble circuit, and check the system any time the EDC relay is activated.

5.3 Beam Interruption Time

The beam interruption time defines the amount of time an intruder must be in the beam path before an alarm is signaled. For instance, if the interruption time is set at 100 ms, the detector signals an alarm only if the beams are broken for more than 100 ms. Refer to *Section 6.2 Interruption Time*.



For UL applications, **do not** set the interrupt time above 75 ms.

5.4 Beam Power Control

The beam strength is at its best level if used at the maximum range [such as 110 m (361 ft) for DS453Q].

If used for shorter distances, excess beam energy reaches the receiver, resulting in reflection on the nearby walls and cross-talk with other detectors.

Beam Power Control adjusts the amount of beam energy for the best detection. Refer to *Section 6.3 Beam Power Control* to set the beam power at the appropriate level.

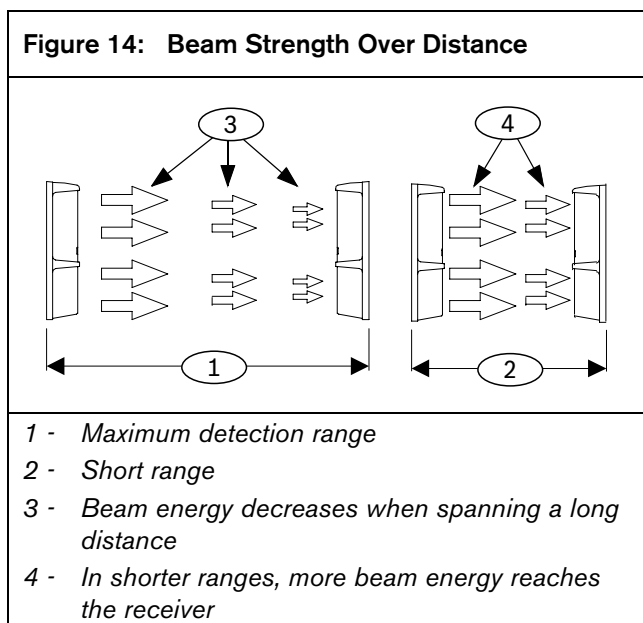

6.0 Setup and Alignment

6.1 Bypass Switch

To activate the Bypass Switch on the receiver, set Switch 1 to ON. Refer to *Figure 15*. To deactivate the bypass switch, set Switch 1 to OFF.

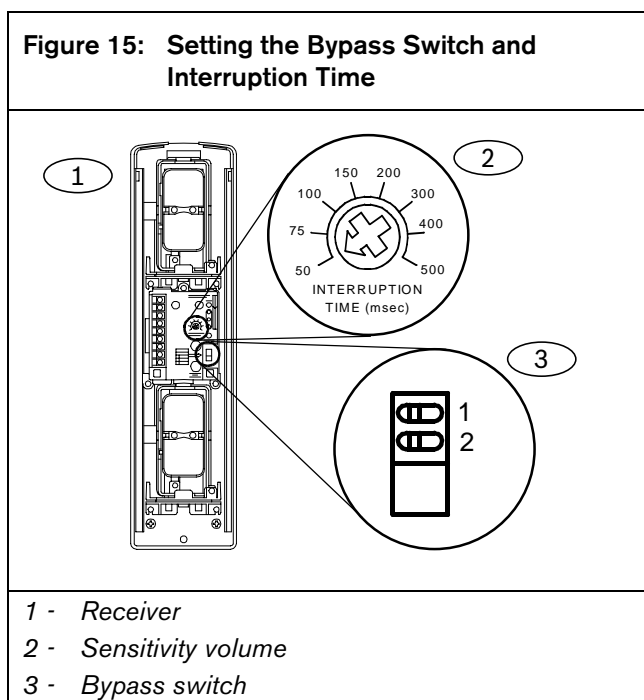

6.2 Interruption Time

Turn the sensitivity volume on the receiver (*Figure 15*) clockwise to reduce sensitivity and counterclockwise to increase sensitivity based on the guidelines in *Table 4*.

Activity	Speed	Sensitivity Volume (Interruption Time)
Running	4 m/s (13 ft/s)	50 ms
Jogging	2 m/s to 3 m/s (7 ft/s to 10 ft/s)	75 ms to 100 ms
Walking	1 m/s to 1.5 m/s (3.28 ft/s to 5 ft/s)	150 ms to 200 ms
Slow Walking	0.5 m/s to 1 m/s (2 ft/s to 3.28 ft/s)	300 ms
Slow Moving	0.5 m/s or less (2 ft/s or less)	400 ms to 500 ms

6.3 Beam Power Control

Turn the Beam Power Control on the transmitter (*Figure 16*) clockwise to increase beam power and counterclockwise to decrease beam power. Refer to *Table 5* to set the volume based on the detection range (initial setting at maximum length).

Table 5: Outdoor Beam Power Control Settings

DS453Q		DS455Q	
Volume Setting	Range	Volume Setting	Range
35	<35 m (115 ft)	50	<50 m (164 ft)
55	35 m to 55 m (115 ft to 181 ft)	80	50 m to 80 m (164 ft to 263 ft)
70	55 m to 70 m (181 ft to 230 ft)	100	80 m to 100 m (163 ft to 328 ft)
85	70 m to 85 m (230 ft to 279 ft)	120	100 m to 120 m (328 ft to 394 ft)
100	85 m to 100 m (279 ft to 328 ft)	140	120 m to 140 m (394 ft to 459 ft)
110	100 m to 110 m (328 ft to 361 ft)	160	140 m to 160 m (459 ft to 525 ft)

Figure 16: Transmitter Beam Power Control

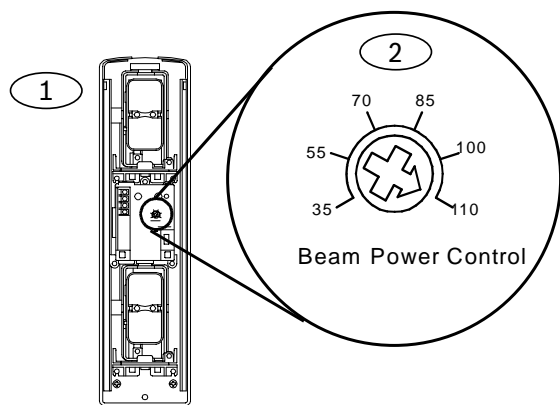

- 1 - Transmitter
- 2 - Beam Power Control

6.4 Alignment

6.4.1 Alignment by LED

1. Apply power to the system.
2. Use the supplied interruption sheets to cover the lower optical modules of the transmitter and the receiver.

Figure 17: Installing the Interruption Sheets

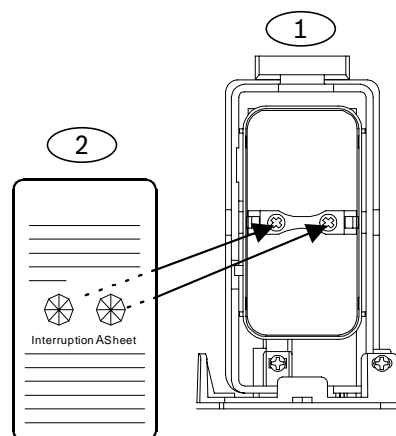

- 1 - Lower optical module
- 2 - Interruption sheet

3. Look into the upper scope of the transmitter 10 cm (3.9 in.) to 15 cm (5.9 in.) from the optical module. Use the turntable to adjust the horizontal angle.
4. Use the horizontal and vertical adjustment screws to locate the receiver in the center of the viewing area.

Figure 18: Alignment Using Scope and LEDs

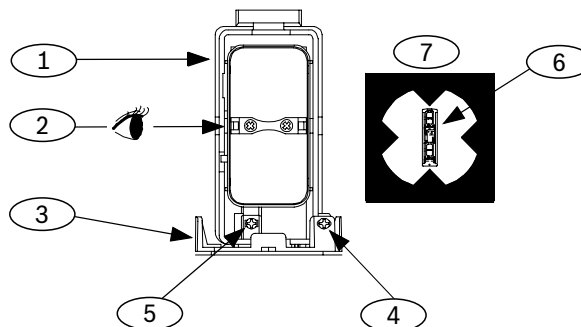

- 1 - Upper optical module
- 2 - Scope (upper)
- 3 - Turntable
- 4 - Horizontal adjustment screw
- 5 - Vertical adjustment screw
- 6 - Image of receiver
- 7 - Viewing area

5. Look at the Level Meter on the receiver to proceed with fine tuning. Refer to *Figure 13* on page 9.
6. Use a screwdriver to adjust the angle of the upper optical module.
7. As more beam energy is received, each LED status follows this sequence:

ON → Flashes quickly → Flashes slowly → OFF

8. Continue fine tuning until all LEDs turn off.
9. Remove the interruption sheets from the lower optical modules and cover the upper optical modules of the transmitter and the receiver. Repeat the alignment process for the lower optical modules.
10. When all LEDs turn off, the alignment is complete. Remove the interruption sheets from the optical modules.

6.4.2 Alignment Using a Voltmeter

1. Apply power to the system.
2. Use the supplied interruption sheets to cover the lower optical modules of the transmitter and the receiver.
3. Insert the voltmeter leads into the alignment check terminals. Refer to *Figure 19*.

Figure 19: Terminals on Receiver Panel

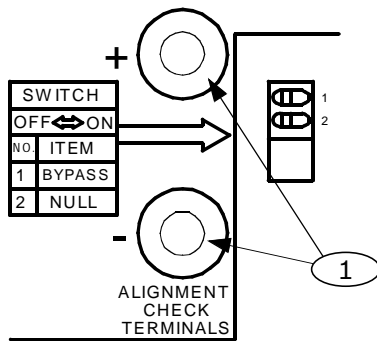

1 - Alignment check terminals

4. Set the voltmeter to 10.0 VDC.
5. Use a screwdriver and adjust the upper optical modules to obtain the maximum voltage.



In an ideal environment, the voltage is 3.0 VDC or above.

6. Remove the interruption sheets from the lower optical modules and cover the upper optical modules of the transmitter and the receiver. Repeat the alignment process for the lower optical modules.



Make sure to remove the interruption sheets and close the covers when alignment is complete.

7.0 Tests

7.1 Walk Test



Inspect the system and perform the walk tests at least once a year.

1. Walk across the beam paths between the transmitter and receiver in three locations. Refer to *Figure 20*.
2. Each time you cross the beam path, the alarm LED turns on.
3. Make sure the control panel receives an alarm signal.

If the alarm LED does not turn on, the beam interruption time is set too slowly or the other beams are reflected into the receiver.



Remove the interruption sheets and close the covers when alignment is complete.

Figure 20: Walk Test

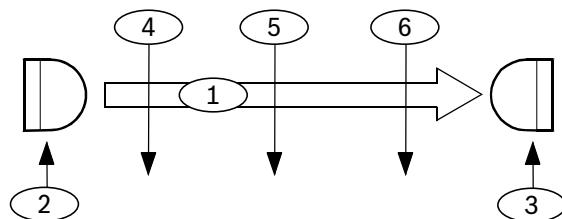

- 1 - Beam path
- 2 - Transmitter
- 3 - Receiver
- 4, 5 and 6 - Walk test crossing locations

7.2 EDC Test

1. Block only the upper optical module of the receiver for 3 seconds. Ensure that the EDC LED on the receiver turns on.
2. When the EDC LED is on, block the lower optical module. Confirm that the alarm LED on the receiver turns on.
3. Block only the lower optical module of the receiver for 3 seconds. Confirm that the EDC LED on the receiver turns on. Confirm that the control panel receives the EDC signal from the receiver.
4. Refer to *Section 5.0 Special Features* on page 9 to confirm that the bypass feature is activated.

7.3 Tamper Test

1. Place the cover on the detector.
2. Confirm that the tamper input of the control panel is in an armed condition.
3. Remove the cover from the detector.
4. Make sure the tamper input of the control panel receives an alarm signal.

8.0 Troubleshooting Guide

In case of trouble, confirm the following:

- The voltage for the transmitter and the receiver is between 10.5 VDC and 28 VDC.
- The monitor LED on the transmitter is ON.
- The alarm LED on receiver turns on when the beams are blocked.
- The volume of beam power control is appropriate for the set range.
- All LEDs on the receiver are OFF.

Problem	Cause	Solution
Constant alarm output	Something is blocking the beams.	Remove the object(s).
	Optical modules or covers need cleaning.	Clean the optical modules and the covers.
False alarms	Unit misaligned.	Realign.
	Something is blocking the beams.	Remove the object(s).
	Beam interruption time is set too fast.	Decrease the sensitivity.
	Nearby electrical equipment is generating EMI or RFI.	Change the installation site.
	Wiring too close to power sources or power line.	Change the wiring route.
	Unstable installation site.	Fix the installation site.
	Inappropriate beam power control level.	Readjust the control level.
	The maximum protection range of the model is exceeded.	Reinstall within the maximum range.
No alarm when beams are broken	Beams are reflected into the receiver.	Remove the reflective object or change the installation site.
	Beam interruption time is set too slowly.	Increase the sensitivity.
	Not enough beam power.	Increase the beam power.
EDC activation	Beam interruption time is set too slowly.	Increase the sensitivity.
	Something is blocking the beams.	Remove the object(s).
	Installed on unstable ground.	Fix the installation site.
	Inappropriate beam power control level.	Readjust the control level.
	The maximum protection range of the model is exceeded.	Reinstall within the maximum range.
	Something is blocking the beams.	Remove the object(s).

9.0 Other Information

- At least once a year, clean the optical modules and covers with a soft cloth. Perform walk testing to confirm operation.
- The specifications can change without notice.
- Because the photoelectric detectors are only part of a complete security system, Bosch Security Systems cannot accept responsibility for any damages or other consequences resulting from an intrusion.

10.0 Specifications

Table 7: Specifications

Table 7: Specifications		
Range (outdoors)	DS453Q	110 m (360 ft)
	DS455Q	160 m (525 ft)
Power Supply	10.5 VDC to 28.0 VDC	
Current Draw (maximum, transmitter & receiver total)	DS453Q	135 mA
	DS455Q	160 mA
Operating Temperature	-25°C to 60°C (-13°F to 140°F)	
Storing Temperature	-30°C to 70°C (-22°F to 158°F)	
Alarm Output	Form C relay rated at 0.2 A @ 30.0 VDC	
Environmental Discrimination Circuit (EDC)	Normally-closed switch for connection to normally-closed supervision circuit. Rated at 0.2 A @ 30.0 VDC	
Tamper	Normally-closed tamper switch rated at 0.1 A @ 30.0 VDC	
Beam Interruption Time	50 ms to 500 ms (adjustable)	
Internal Pointability	180° horizontal, 20° vertical	
Beam Power Control	Equipped	
Weight (transmitter & receiver total)	2.4 kg (5.3 lb)	
Dimensions (HxWxD)	39.8 cm x 10 cm x 10 cm (15.7 in. x 4 in. x 4 in.)	

Notes

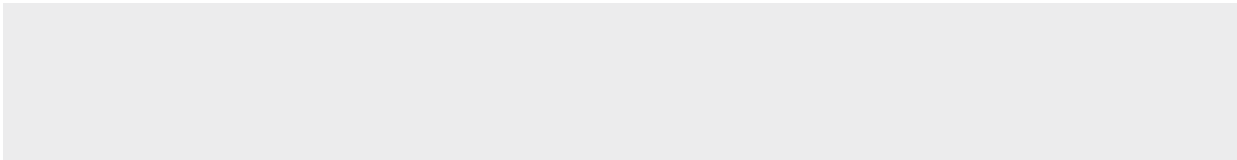

Bosch Security Systems, Inc.
130 Perinton Parkway
Fairport, NY 14450-9199
Customer Service: (800) 289-0096
Technical Support: (888) 886-6189

© 2005 Bosch Security Systems
4998147984C



BOSCH